



Electrical Information					
Model No.	UWP05-010	UWP05-020	UWP05-030	UWP05-040	UWP05-070
Power Consumption(±10%)	10W	20W	30W	40W	70W (±5%)
Power Supply	Daermay				
Input Voltage	100-240 VAC / 200-240 VAC ,50 / 60 Hz				
Power Factor	≥0.9 at Max Load				
Surge Protection	1KV line-line, 2KV line-earth				
Driver Type	Constant Current (CC)				
Control	Photocell Control				

Optic Information					
LED Type	LED 3030				
Luminous Flux (±10%)	1250LM	2500LM	3750LM	5000LM	8750LM
Efficacy (5000K Ra70)	125LM/W				
Correlated Color Temperature	5000K (4000K optional)				
Color Rendering Index	Ra70				
Beam Angle	U04201			R08401	
UGR level	NA				

Description

AGC's LED Slim Wall Pack light is low profile, light weight, and designed for long life usage with no maintenance and great performance. This light is designed to quickly and easily upgrade traditional Slim Wall Pack light fixtures.

Key Features

- Silver cast-aluminum fixture is durable
- High Lumen output
- Special-designed PC optics lens (TYPE III Distribution)
- For Security/pathway and Perimeter lighting/building facades

Applications

- Security
- Pathway and Perimeter lighting
- Building facades

Dimensions and Mount

Product Dimension	196 x 96 x 186mm			282 x 125 x 205mm	
Luminaire Net Weight	1.39±0.2kg	1.44±0.2kg	1.48±0.2kg	2.82±0.2kg	3.04±0.2kg
Export Carton Size	10/20/30W	515x405x240mm(6pcs/ctn)			
	40/70W	330x155x235mm(1pcs/ctn)			
Gross Weight	10.55±0.2kg (6pcs/ctn)	10.85±0.2kg (6pcs/ctn)	11.03±0.2kg (6pcs/ctn)	3.13±0.2kg (1pcs/ctn)	3.35±0.2kg (1pcs/ctn)
Mounting Option	Junction boxes or Surface mounting				
Material	Cast Aluminum				
	Polycarbonate Optical Lens				
Finish	Powder Coating				
Fixture Color	Silver				
EPA	NA				
IK Rating	IK08				
IP Rating	IP66				

Lifespan and Warranty

Operating Temperature	-30°C to + 45°C
Life Time of LED @Ta=25°C	48,000hrs-L90
	100,000hrs-L80
	158,000hrs-L70
Warranty	5 Years

New Features

* Please consult us for details.

Photometry

10W/20W/30W

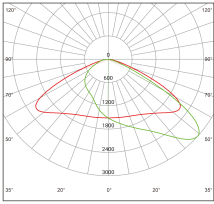

U04201

40W/70W

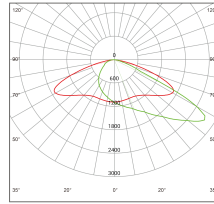

R08401

Mounting Options and Dimensions

Unit: mm

10W/20W/30W

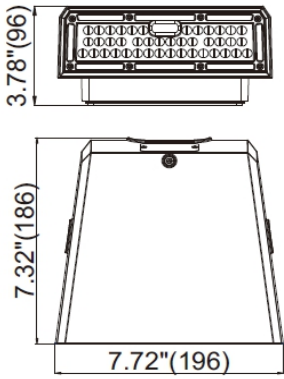

40W/70W

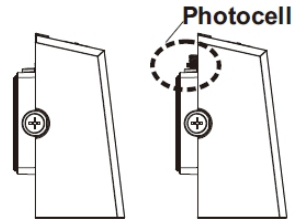
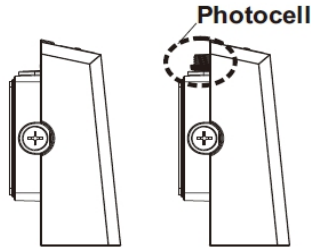
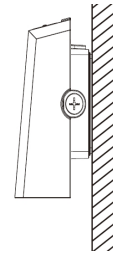
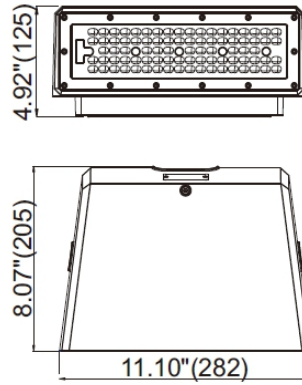

Accessories

